

Lifting Station Type ABS Piranhamat 100 and 120

Compact faecal pumping unit for direct connection of one WC in accordance with EN 12050-3. Suitable also for connection of a wash-hand basin, shower and bidet.

Applications

The Piranhamat 100/120 pumping unit has been designed for the removal of effluent from a WC located below the sewer backwash level or where the effluent cannot flow by gravity into a sewer. It is also possible to connect one wash-hand basin, one shower, and one bidet to the unit. Thanks to its compact design and the use of small bore piping, the Piranhamat 100/120 pumping unit is suitable for installation in an existing house or during the renovation of old buildings. Where usage is by members of the public and cannot be monitored, or where more effluent sources are to be connected, installation of the Sanimat series is recommended.

Construction

- Modern, gas- and odour-tight white plastic tank of high quality synthetic material, resistant to all common toilet cleaning fluids.
- Ready for use, and fitted with a powerful Piranha grinder pump which is controlled automatically by the integral level control system.
- Push-on, self-sealing connection for a toilet at the rear of the unit, and push-in connection ports for one wash-hand basin, one shower and one bidet at the sides. The discharge connection can be made on either side of the unit and means that the discharge pipe can exit left or right as is found most suitable for the particular installation.
- Equipped with an electronic control unit with high level alarm (Piranhamat 120 with additional alarm buzzer).
- Non-return flap valve on the discharge line.
- Maximum allowable temperature of the medium is 40 °C; or up to 60 °C for a maximum of five minutes.

The Piranha pump itself is fitted with a special shredding device that reduces the medium to a size that can easily be pumped through a small bore pipe system of a size from 25 mm diameter. This ensures blockage-free disposal of faecal matter, toilet paper of various thicknesses, and also sanitary articles which might be accidentally dropped into the toilet.



Features

- Compact unit ready to plug in and suitable for direct euro toilet connection.
- With Sulzer patented Piranha cutting system for pumping faecal matter and also sanitary articles that might be accidentally dropped into the toilet.
- Automatic level control and alarm.
- Attractive corrosion-resistant synthetic tank.
- Maintenance-friendly unit with easy access lid (no screws).
- Carbon filter fitted to reduce odours.
- Non-return valve and 2 m cable with Schuko plug supplied as standard.

Installation

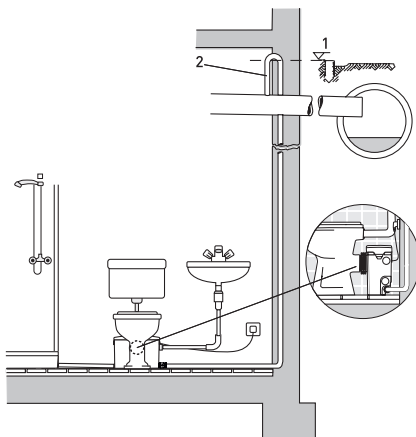

1. Backwash level
2. Backwash loop with base above the backwash level

Performance Curve

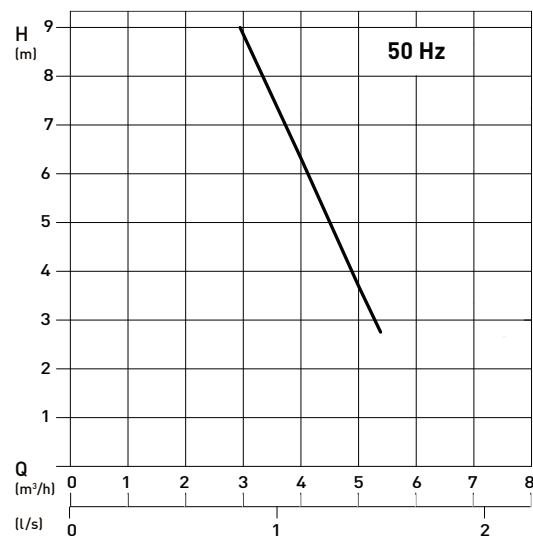

H = Total Head; Q = Discharge Volume
Curves to ISO 9906 (60z available on request)

Technical Data

Piranhamat	100 and 120
Motor power * (kW)	$P_1 = 1.1$ $P_2 = 0.68$
Speed (r/min)	2900
Rated voltage (V)	220-240 1~
Rated current (A)	4.84
Cable length (m)	2.2
Cable type (H05V V-F)	3G1.0
Weight (kg)	9.0

* P_1 = Power taken from mains; P_2 = Power at motor shaft

Dimensions (mm)

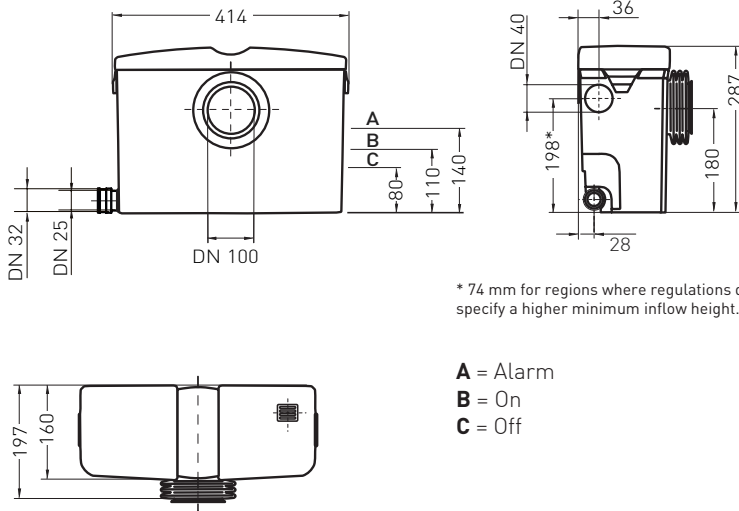

* 74 mm for regions where regulations do not specify a higher minimum inflow height.

Note:

In the case of power failure, by driving the rotor shaft with an electric drill, the hydraulic system of the Piranhamat 100/120 will be operated and the tank emptied.

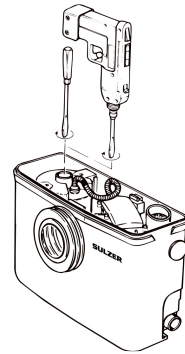

Discharge Lines

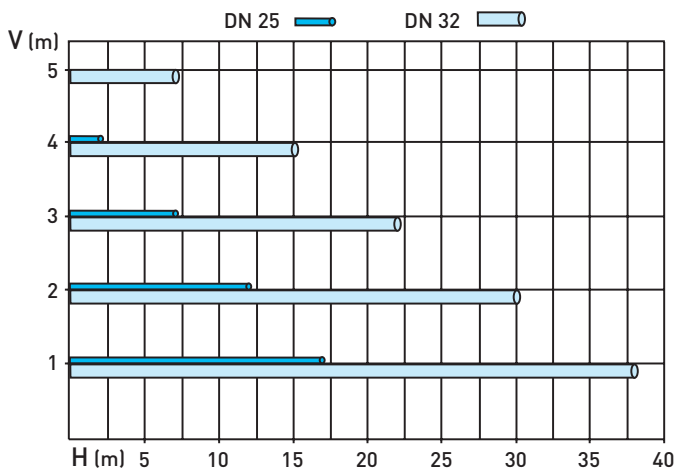

Maximum pipe length allowable for the optimum functioning of the unit. Allowance has been made for two 90° bends and one Sulzer non-return valve.

V = Vertical discharge line length
H = Horizontal discharge line length

SULZER